



Arenco VMK Automatic Filleting Line

The Arenco VMK Automatic filleting line is a high-precision combination automatic feeding, heading and filleting machine which produces high-yield butterfly or single fillets with a clean, smooth appearance. The versatile Arenco VMK automatic filleting line may also be configured with skinner piece cutter to produce skin-off fillets and/or tit bits. Deli style dressed fish may also be produced, utilizing a brush and grindstone to carefully clean out belly cavity. The Arenco VMK automatic filleting line can do 330 fish/minute and when utilized together with Arenco VMK Vision System. The unit is capable of processing up to 6 machines and 330 fish per minute/machine with only one operator.

If required, the filleting section may be operated as a hand-fed stand alone machine.

Species handling capabilities include herring, mackerel, horse mackerel, blue whiting, and similar species. The machine can also be configured to process smaller fish, such as sardine, anchovy, kilka and sardinella.

The Arenco VMK Automatic filleting line is made of all non corrosive material and complies all CE machinery directives

Arenco VMK Fish Concept

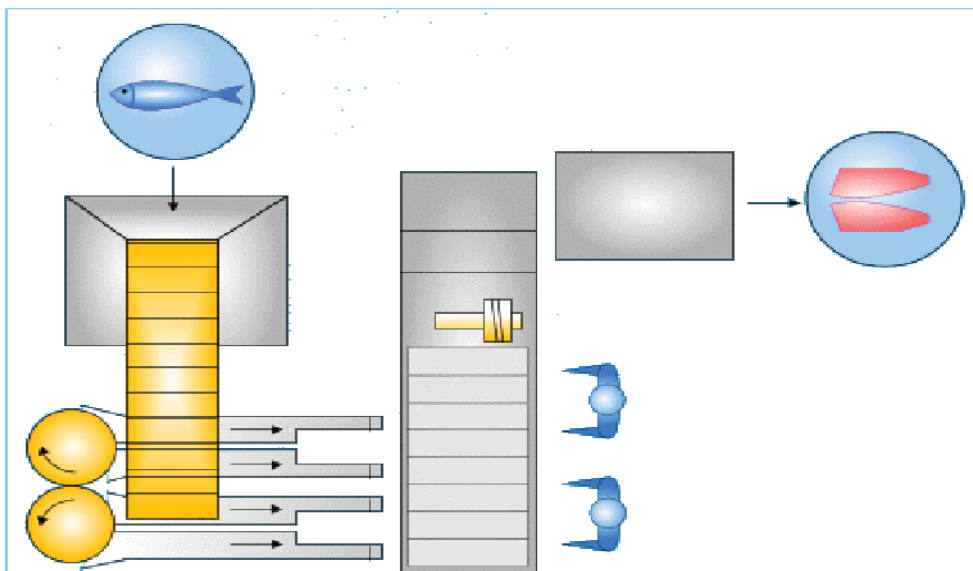

Arenco VMK Automatic Filing line

Technical Specifications

Manual

Water Connection	25 mm
Water Usage	30 liters per minute
Electrical	Per customer specifications
Power	4.1 kW @ 50Hz 4.8 kW @ 60Hz
Operators	3
Net Weight	1 170 kg Crated 1 620 kg

Automatic

Water Connection	25 mm
Water Usage	42 liters per minute
Electrical	Per customer specifications
Power	6 kW @ 50Hz 7 kW @ 60Hz
Operators	1
Net Weight	2 230 kg Crated 3 290 kg

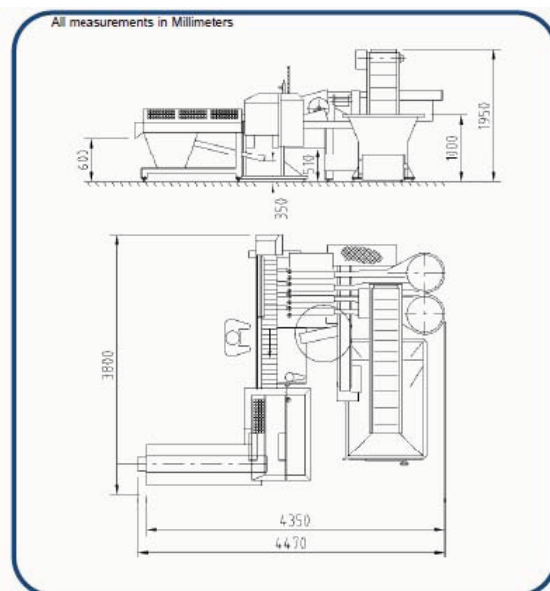
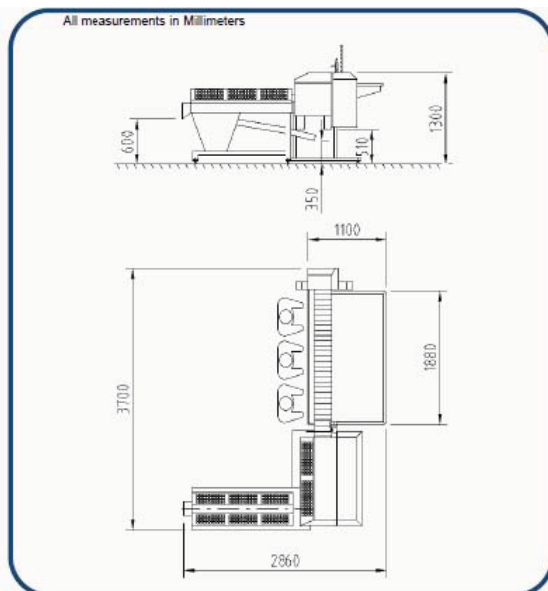

Arenco AB

Datavägen 57 B, SE- 436 32 Askim
Sweden

Phone: +46 31 748 03 18

Fax: +46 31 748 03 10

Web: www.arenco.com

